

**SPECIFICATION DATA MOTORS TYPE MAP**

Intermittent values

Continuous values

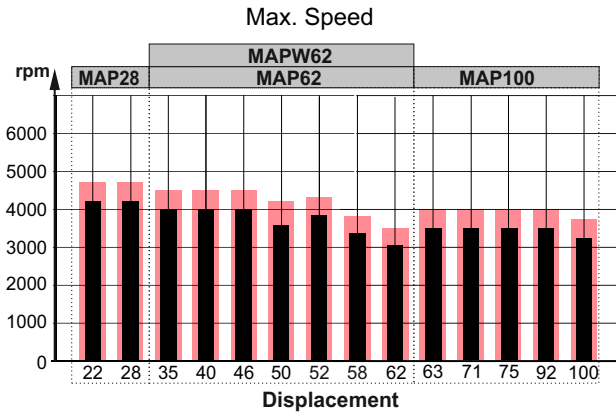
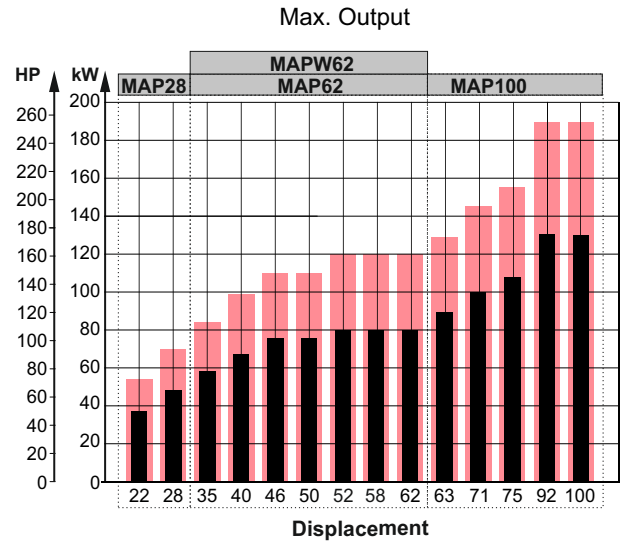
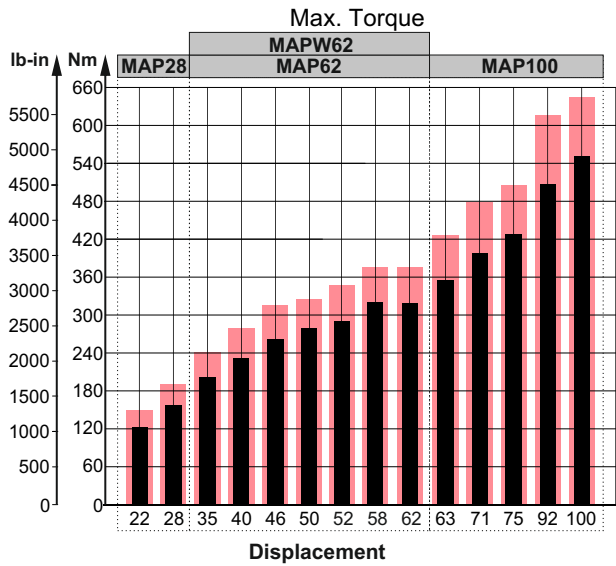

**Specification Data Pumps Type PAP**

Intermittent values

Continuous values

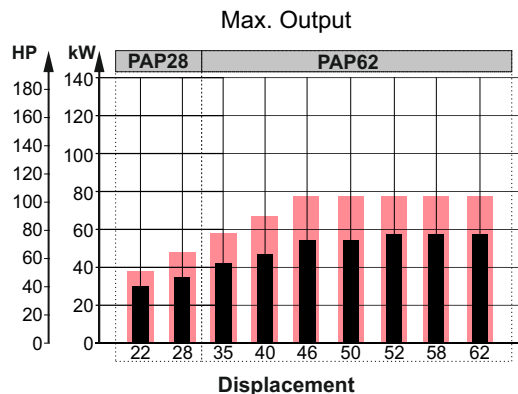
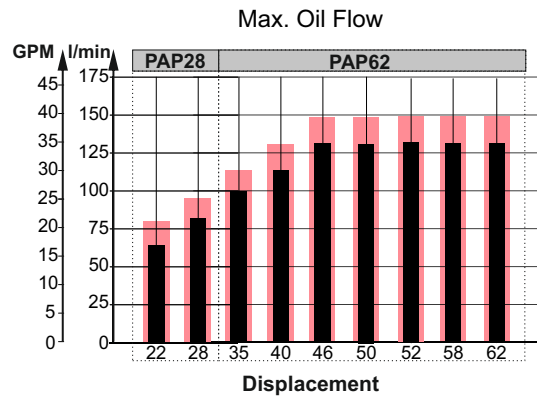
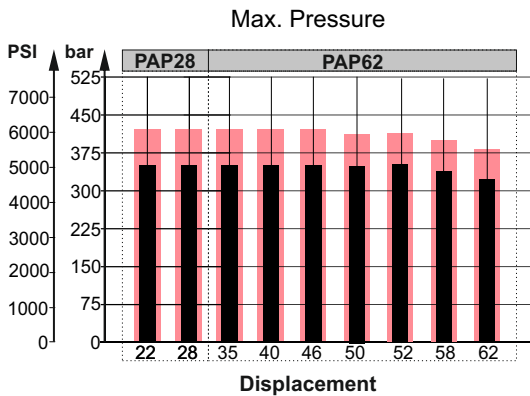

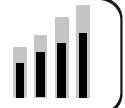

**PORT, SHAFT AND FLANGE TYPES**

PORTS SIZE - THREAD OPTION		Type of threads
PAP28	PAP62	
default		Inlet ISO 6162-1 DN32, Outlet ISO 6162-2 DN19, drain ports M18x1.5
5		Inlet SAE J518 1 1/2 PSI3000, Outlet SAE J518 3/4 PSI6000, drain ports 7/8-14 UNF
9		Inlet ISO 6162-1 DN32, Outlet ISO 6162-2 DN19, drain ports G1/2
	default	Inlet ISO 6162-1 DN38, Outlet ISO 6162-2 DN19, drain ports M18x1.5
	5	Inlet SAE J518 1 1/2 PSI3000, Outlet SAE J518 3/4 PSI6000, drain ports 7/8-14 UNF
	9	Inlet ISO 6162-1 DN38, Outlet ISO 6162-2 DN19, drain ports G1/2

**Cross Table - Port Types For Pumps**

**VALVE OPTIONS FOR MOTORS**

**Anti-Cavitation Valve**

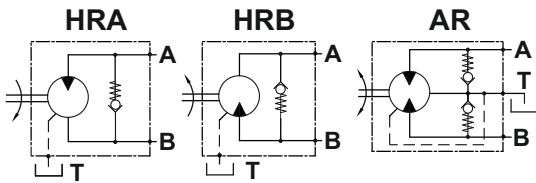

**Combined Anti-Cavitation and Relief Valve**

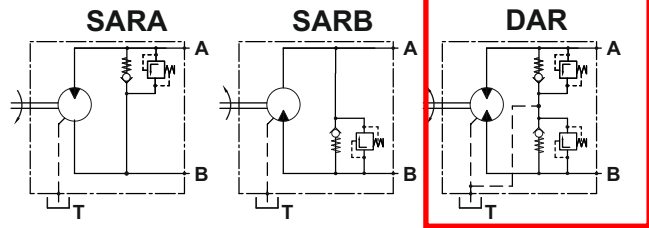

**Purge Valve**

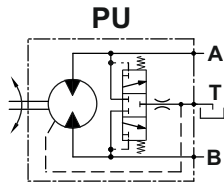

**Flush Valve**

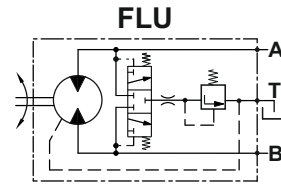

**Dual Anti-Cavitation, Relief and Purge Valve**

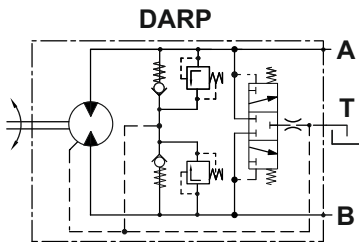

**Dual Anti-Cavitation, Relief and Flush Valve**

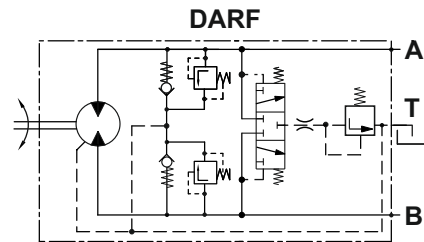

**Cross Table - Valve Types**

Type of valves	MAP28			MAP62			MAP100			MAPW62		
	omit	T	E	omit	T	E	omit	T	E	omit	T	E
HRA	x	x	x	x	x	x	x	x	x	x	x	x
HRB	x	x	x	x	x	x	x	x	x	x	x	x
AR	x	x		x	x	x	x	x	x	x	x	x
SARA	x	x		x	x	x	x	x	x	x	x	x
SARB	x	x		x	x	x	x	x	x	x	x	x
<b>DAR</b>	<b>x</b>	<b>x</b>		x	x	x	x	x	x	x	x	x
PU	x	x	x	x	x	x	x	x	x	x	x	x
FLU	x	x	x	x	x	x	x	x	x	x	x	x
DARP		x		x	x		x	x	x	x	x	
DARF		x		x	x		x	x	x	x	x	



# Hydraulic Motors Type MAP28

## Heavy Duty Axial Piston Motors Fixed Displacement

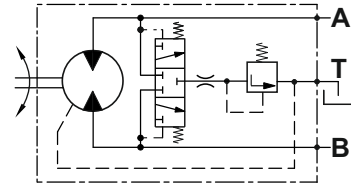
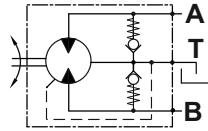
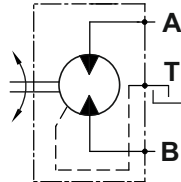

open drain line is always required

### APPLICATION

- » Agricultural machines
- » Road building machines
- » Mining machinery
- » Food industry machines
- » Swing drives
- » Hydraulic transmissions
- » Vibration machines
- » Fan drives
- » Special vehicles

### OPTIONS

- » Flange options
- » Port options
- » Shaft options
- » High pressure ports
- » Integrated valves

### ADVANTAGES

- » High starting torque
- » Smooth operation
- » Long service life
- » High power density

### GENERAL

Displacement,	cm <sup>3</sup> /rev [in <sup>3</sup> /rev]	22.15÷28.47 [1.35÷1.74]
Max. Speed,	RPM	4200
Max. Torque,	Nm [lb-in]	159 [1407]
Max. Output,	kW [HP]	48 [64]
Max. Pressure Drop,	bar [PSI]	350 [5080]
Max. Oil Flow,	l/min [GPM]	120 [31.7]
Min. Speed,	RPM	500
Fluid	Mineral based- HLP(DIN 51524) or HM(ISO 6743/4)	
Temperature Range,	°C [°F]	-40÷82 [-40÷180]
Optimal Viscosity Range,	mm <sup>2</sup> /s [SUS]	12÷68 [66÷311]
Filtration	ISO code 18/16/13 (Min. recommended fluid filtration of 10 micron)	

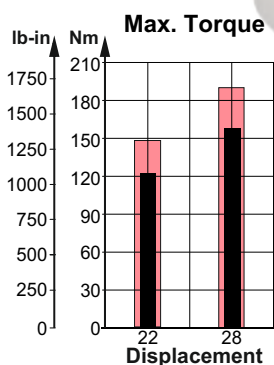

Intermittent values

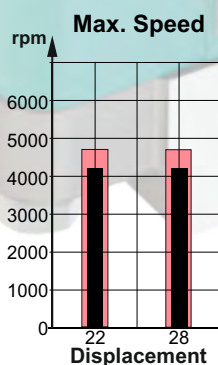

Continuous values

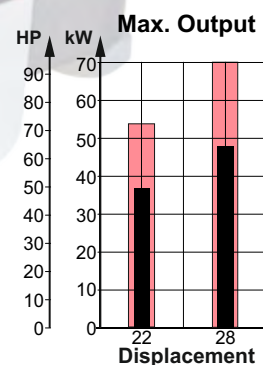



## SECTION VIEW

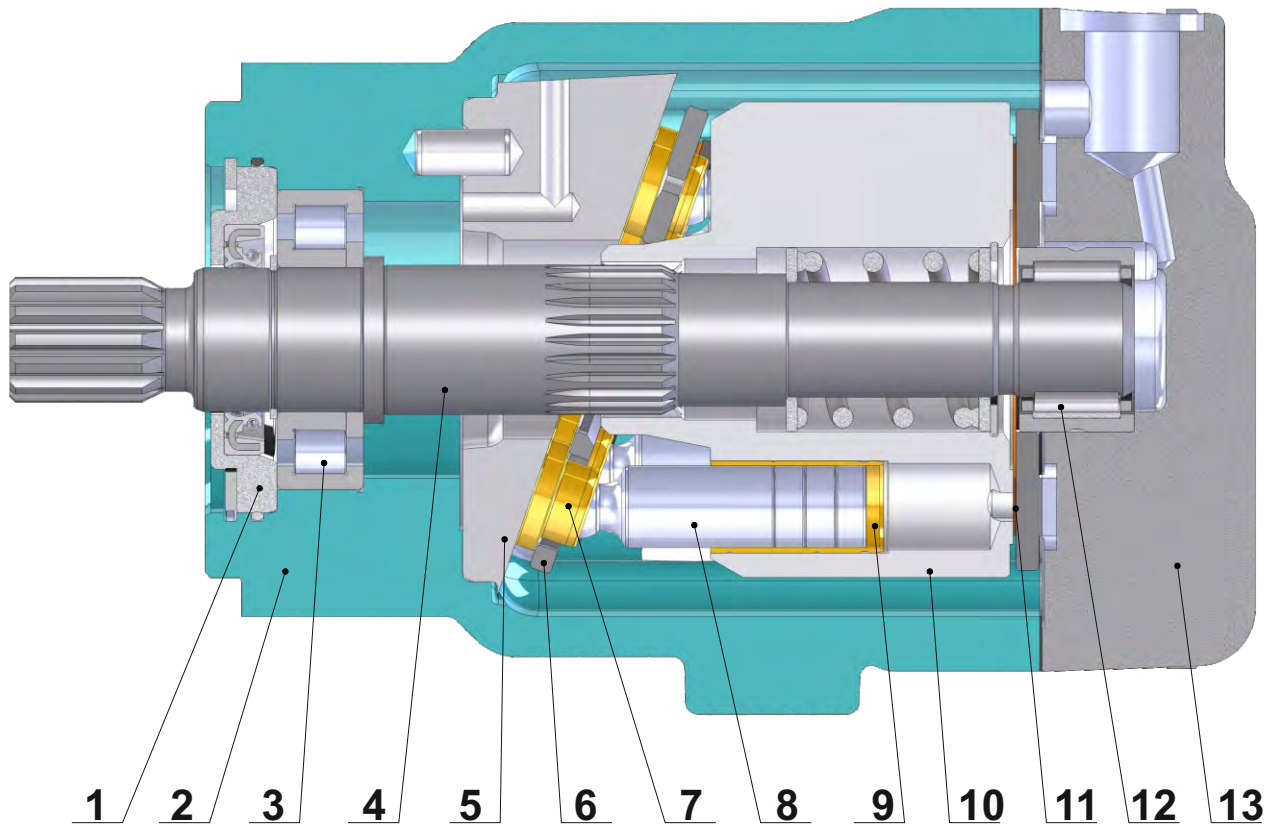

1. Front cover
2. Cast iron body
3. Robust radial - axial roller bearing
4. Hardened shaft
5. Solid swash plate
6. Retainer plate
7. Improved piston shoes
8. Improved pistons
9. Brass bushings
10. Hardened steel cylinder block
11. Bimetal distributor
12. Needle bearing
13. Solid end cover

The main advantages of the heavy duty design of the MAP motors over the typical swash plate motors are the higher starting torque and the higher total efficiency. In regards to these two parameters, under normal working mode, the MAP is comparable to the bent axis motors. The advantages of the MAP over the bent axis motors are the higher reliability and the lower degree of pulsation and vibration during operation.



**SPECIFICATION DATA**

Type		MAP 22	MAP 28
Displacement, cm <sup>3</sup> /rev [in <sup>3</sup> /rev]		22.15 [1.35]	28.47 [1.74]
Max. Speed, [RPM]	Cont.	4200	4200
	Int.*	4700	4700
Max. Torque,** Nm [lb-in]	Cont.	123 [1088]	159 [1407]
	Int.**	148 [1310]	190 [1682]
Output, kW [HP]	Cont.	37 [50]	48 [64]
	Int.**	54 [72]	70 [94]
Max. Pressure, bar [PSI]	Cont.	350 [5080]	350 [5080]
	Int.**	420 [6100]	420 [6100]
	Peak	450 [6527]	450 [6527]
Max. Oil Flow, l/min[GPM]	Cont.	93 [24.6]	120 [31.7]
	Int.*	104 [27.5]	134 [35.4]
Torque Constant ***** Nm/bar [lb-in/PSI]		0.32 [0.194]	0.41 [0.25]
Speed Constant ***** RPM/(l/min) [RPM/GPM]		42.9 [162.4]	33.4 [126.3]
Permissible Shaft Load	max Axial**** N[lb]	Fa=1300 [292]	
	max Radial**** N[lb]	Fr=2200 [495]	
Min. Speed, [RPM]		500	
Max. Pressure in Drain Line, bar [PSI]		5 [70] open drain line is always required	
Weight, kg [lb]		10.79 [23.79] for SAE-A flange	
		11.50 [25.35] for SAE-B flange	

Peak pressure is the highest allowable pressure, may occur for max. 1% of every minute;

\* Intermittent speed (flow): for pressure up to 150[2200] bar[PSI];

\*\* Intermittent load: the permissible values may occur for max. 10% of motor lifetime;

\*\*\* Theoretical torque;

\*\*\*\* The calculated max values are based on the optimal direction of the forces Fr, Fa and optimal position of the shaft.

\*\*\*\*\* The constant values are used for calculation of torque and speed with motor efficiencies  $\eta_v=0.95$  and  $\eta_{mh}=0.9$ .

1. The recommended output power for continuous operations should not be exceeded.
2. Recommended filtration as per ISO 4406 cleanliness code 18/16/13 or better. This filtration corresponds to SAE AS 4059 8A/7B/7C. Nominal filtration - 10 micron or better.
3. Recommended a premium quality, anti-wear type mineral based hydraulic oil, HLP(DIN51524) or HM(ISO6743/4).
4. Recommended oil viscosity - 12...68 cSt or see page 84.
5. Recommended maximum system operating temperature - 82°[180°] C[F].
6. To ensure optimum life of the motor, fill it up with fluid prior to load it and run with moderate load and speed for about 10-15 minutes.

Hint: Motor Torque = Torque Constant \* Pressure Drop

Rotation Speed = Speed Constant \* Oil Flow

The constant values are approximate. Motor torque and rotation speed for a particular project are depending on the real operating conditions. For more detailed calculations please see efficiencies on page 74 and formulas on page 85.



**OVERALL DIMENSIONS AND PORTS**

**Twin Side Ports - Type T Mounting Flange - Type SAE-B**

**Twin side ports T, port size 2,3,4 and 6**

See the port sizes at the bottom of this page

**Standard Rotation**  
Viewed from shaft end  
Port A Pressurized - CW  
Port B Pressurized - CCW  
see page 81

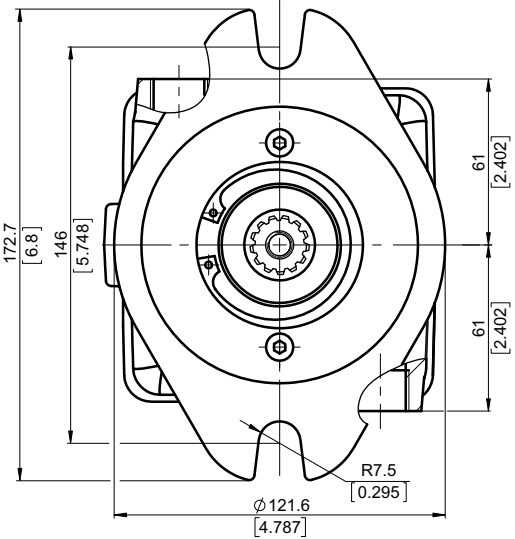
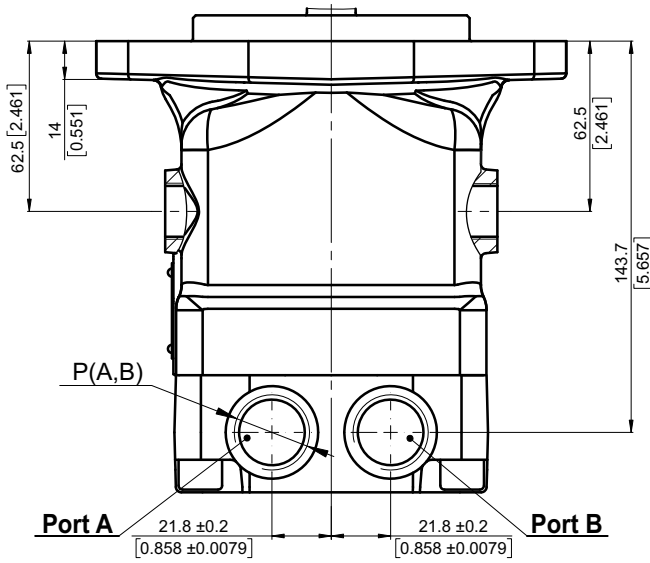
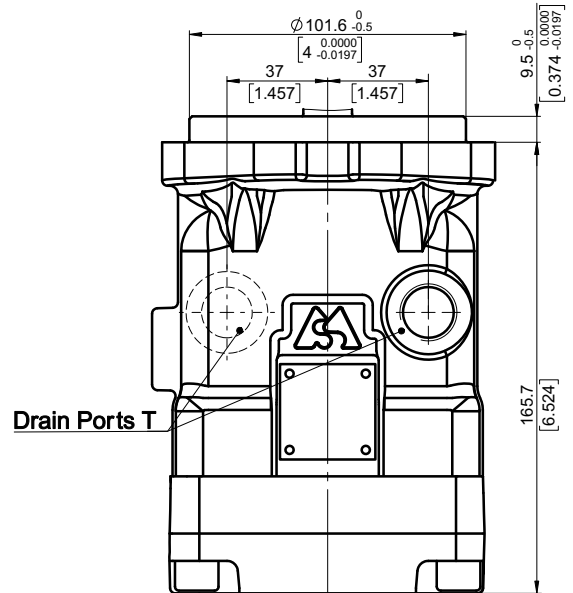
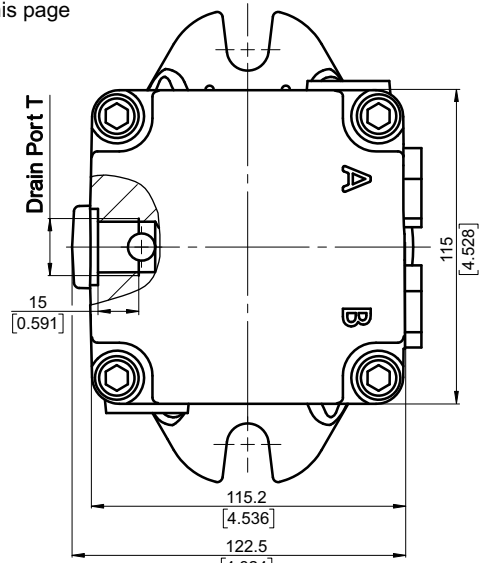
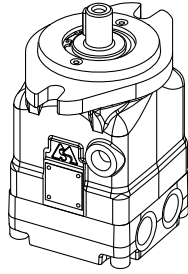

		Port Size			
		2	3	4	6
P <sub>(A,B)</sub>	2xG 1/2	2xM22x1.5	2x7/8-14UNF	2xG 3/4	
T	G 1/2	M18x1.5	3/4-16UNF	G 1/2	

Shaft Mounting  
see the next page

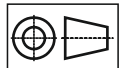

mm [in]



**SHAFTS MOUNTING**

Mounting Flange - Type **SAE-B**

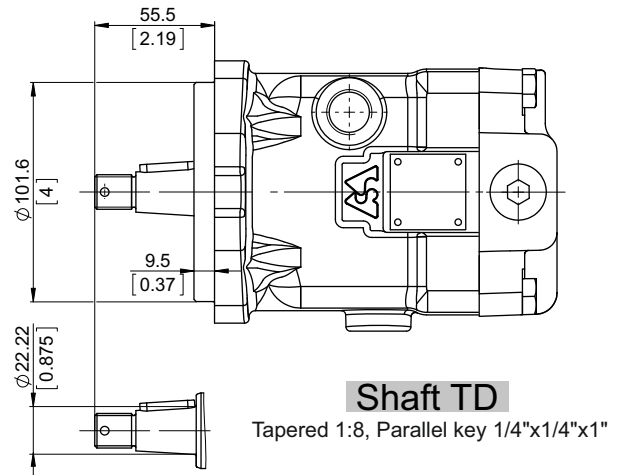
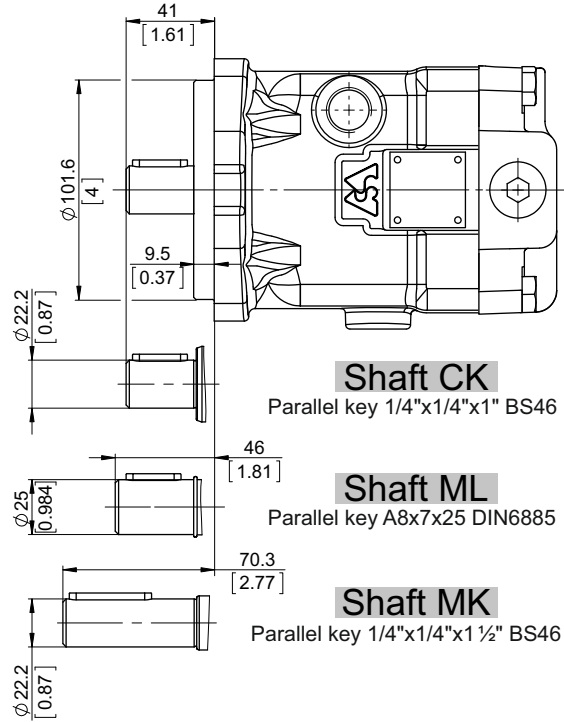
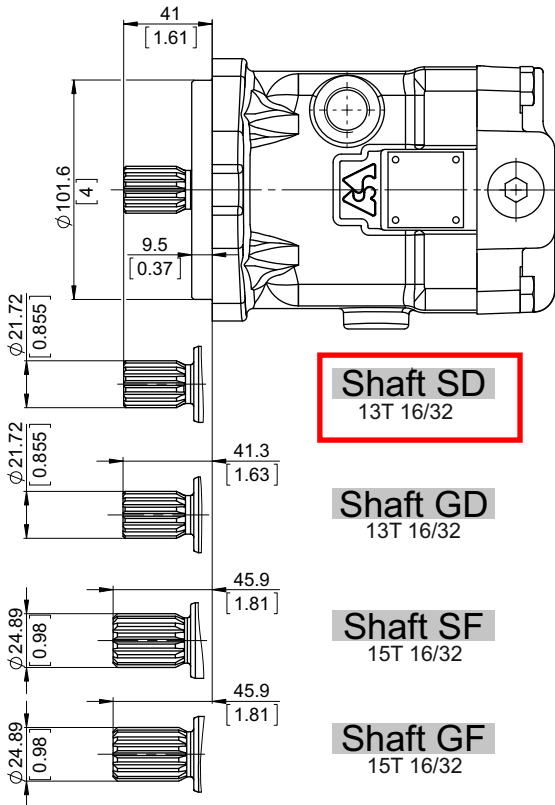

Shaft Dimensions  
See Page 69+73

**PERMISSIBLE SHAFT LOAD**

Permissible shaft load		Standard bearing
max Axial	N[lb]	Fa=1300 [292]
max Radial	N[lb]	Fr=2200 [495]

The calculated max values are based on the optimal direction of the forces Fr, Fa and optimal position of the shaft (see page 81).

For more information, please, feel free to contact us.

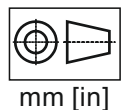



ORDERING CODE

	1	2	3	4	5	6	7	8	9	10	11	12	13	13	13
M	A	P											[		]

Pos.1 - Mounting Flange

- A** - 2-Bolt flange, SAE A, spigot dia. 82.5 [3.25"], BC 106.35 [4.19"], Bolt Dia. 13.5 [0.53"]
- B** - 2-Bolt flange, SAE B, spigot dia. 101.6 [4"], BC 146 [5.748"], Bolt Dia. 14.3 [0.563"]

Pos.2 - Port Type

- omit - Side ports on opposite sides
- T** - Twin (Two) side ports on one side
- E** - Rear ports

Pos.3 - Displacement Code

- 22** - 22.15 cm<sup>3</sup>/rev [1.35 in<sup>3</sup>/rev]
- 28** - 28.47 cm<sup>3</sup>/rev [1.74 in<sup>3</sup>/rev]

Pos.4 - Shaft Extensions\*\*

- SD** - ø21.72 [0.855"] Spline SAE 13T 16/32 DP, M8 thread
- GD** - ø21.72 [0.855"] Spline SAE 13T 16/32 DP, 5/16-18 UNC thread
- SF** - ø24.9 [0.98"] Spline SAE 15T 16/32, M8 thread
- GF** - ø24.9 [0.98"] Spline SAE 15T 16/32, 3/8-16UNC thread
- CK** - ø22.2 [7/8"] Straight, M8 thread Parallel key 1/4"x1/4"x1" BS46
- MK** - ø22.2 [7/8"] Straight, M8 thread Parallel key 1/4"x1/4"x1 1/2" BS46
- ML** - ø25 [0.984"] Straight, M8 thread Parallel key A8x7x25 DIN6885
- CMN** - ø25.4 [1"] Straight, M8 thread Parallel key 1/4"x1/4"x1" BS46
- TD** - ø22.22 [7/8"] Tapered 1:8 [125:1000], Parallel key 1/4"x1/4"x1", 5/8-18 UNF-2A

Shaft type CMN is available only for Pos.1 option A

Pos.5 - Port Size

- omit - 2xISO 6162-2 DN13, drain port M18x1.5
- 2** - 2xG1/2, drain ports G1/2
- 3** - 2xM22x2, drain ports M18x1.5
- 4** - 2x7/8-14 UNF Ports, drain ports 3/4-16 UNF
- 5** - 2xSAE 1/2" PSI6000, drain ports 3/4-16 UNF
- 6** - 2xG3/4, drain ports G1/2
- 9** - 2xISO 6162-2 DN13, drain port G1/2

Option omit;5 and 9 are not available for Pos.2 option T

Pos.6 - Seal, Corrosion Resistant Seal Surface

- omit - NBR seal type material
- V** - FKM seal type material

Pos.7 - Integrated Valves

See page 77+78 for information about valves

- omit - None
- HR** - Single anti-cavitation valve
- AR** - Dual anti-cavitation valve
- PU** - Purge valve - default - 5±2 l/min
- FLU** - Flush valve - default - 5±2 l/min at 20 bar
- SAR** - Single anti-cavitation and relief valve
- DAR** - Dual anti-cavitation and relief valve
- DARP** - Dual anti-cavitation, relief and purge valve, default flow - 5±2 l/min
- DARF** - Dual anti-cavitation, relief and flush valve, default flow - 5±2 l/min at 20 bar

Option DAR, SAR, AR and HR are not available for Pos.2 option E  
Option FLU are not available for Pos.2 option E combine with Pos.5 option 1 and 5  
Option DARF and DARP are available only for Pos.2 option T

Pos.8 - Valve Ports for Single Valves

- omit - None
- A** - Port A
- B** - Port B

Pos.9 - Pressure Setting of Integrated Valves

- omit - None
- x** - 250 300 **350\***

\* 350 bar option are available only for Pos.2 option T. for more information see page

Pos.10 - Flow Setting of Integrated Valves

- omit - None
- Lx** - For value - see page

Pos.11 - Special Features\*

- omit - None
- R2S** - Speed Sensor Two Directional
- R** - Reverse Rotation

Pos.12 - Paint and Coating

- omit - No paint or coating
- P** - Painted
- PC** - Corrosion protected paint

If a painting option is required, the standard color is black-Alkyd-Styrenated Enamel, Black RAL 9005. Other colors - on customer's request.

Pos.13 - Design Series

- omit - Factory specified

\*\*The permissible output torque for shafts must not be exceeded!

EXAMPLE

MAPB28SD2

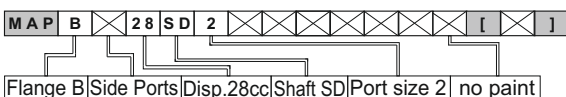

MAPAE22SD4P

